

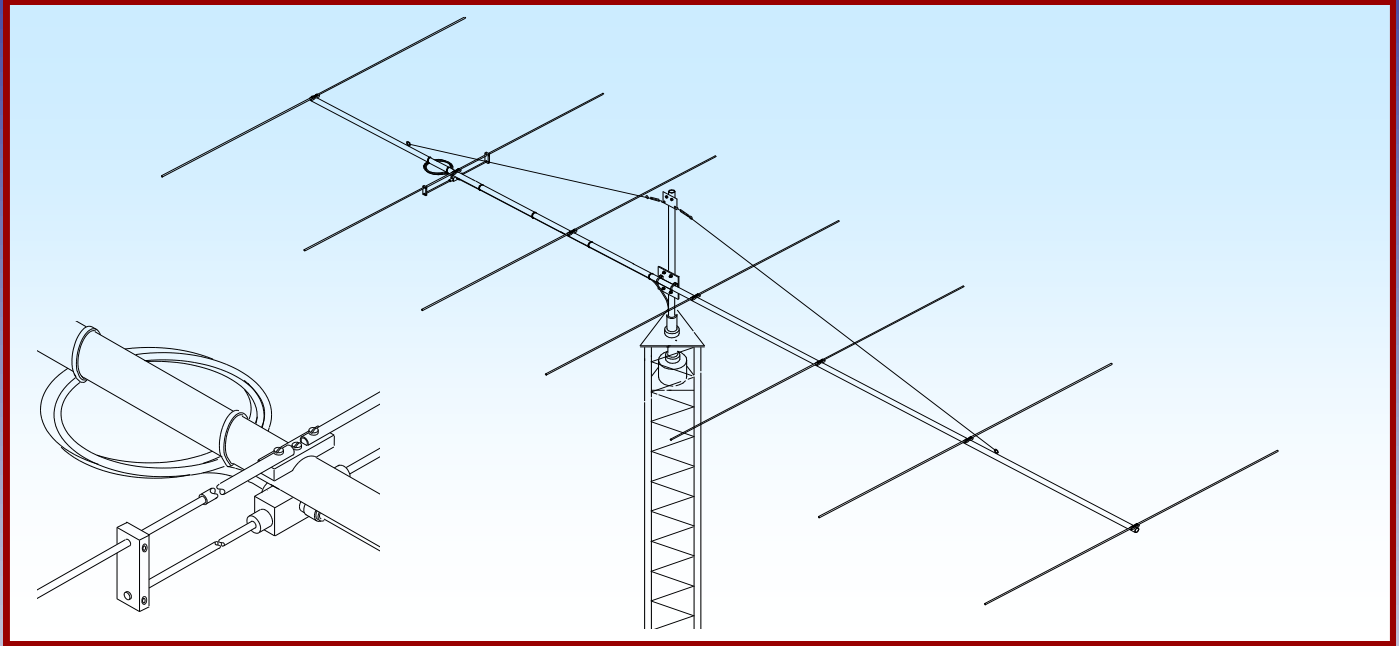

M2 Antenna Systems, Inc.

Model No: 6M7JHV

With new FT8 Dimensions



SPECIFICATIONS:

Model	6M7JHV	Power Handling	1.5 kW
Frequency Range	50.0 To 50.4 MHz	Boom Length / Dia	30' 8" / 1-1/2"
*Gain	13.0 dBi	Maximum Element Length.....	9' 6"
Front to back	25 dB Typical	Turning Radius:	17' 2"
Beamwidth	E=40° H=42°	Stacking Distance	25' High & 27' Wide
Feed type	"T" Match	Mast Size	1-1/2" to 2" Nom.
Feed Impedance.	50 Ohms Unbalanced	Wind area / Survival	2.5 Sq. Ft. / 85 MPH
Maximum VSWR.....	1.2:1 Typical	Weight / Ship Wt.....	18 Lbs. / 21 Lbs.
Input Connector.....	"N" Female		

***Subtract 2.14 from dBi for dBd**

FEATURES:

The 6M7JHV is a mid-sized 7 element antenna designed originally for the late Dave Batcho, N5JHV. The JHV's excellent gain is coupled with a very clean pattern for reducing local noise, making it ideal for long-haul terrestrial and EME communications. An outstanding performer by itself, the JHV also produces 17 dBd in an 4-bay array. Mechanical features include machined aluminum element-mounting blocks, O-ring sealed connectors and balun, silicone-gel sealed T- match block, and stainless steel hardware. Elements are 3/8 tube and DC grounded. The 1-1/2" boom breaks down into 5 ft sections for easy portability. An overhead guy system provides additional boom support. It has become the standard of choice for HF/50 MHz DXpeditions. **M2 now offers an alternate dimension set for the 6M7JHV which is optimized for FT8, yet still provides a good match for SSB/CW. The user can leave the antenna as/is or shorten the elements for a better match higher in the band.**

6M7JHV ASSEMBLY MANUAL

TOOLS REQUIRED: Phillips screwdriver, 11/32 wrench, socket or spintite, a 7/16" and 1/2" wrench or socket, tape measure.

1. Layout the boom sections as shown on Dimension Sheet and assemble with 8-32 x 1-3/4" screws, lockwashers and nuts. Tighten the nuts securely.
2. Note: M2 has provided the two dimension sheets the standard SSB and the FT8 trim to dimensions. Use the appropriate Dimension Sheet as reference for installing the ELEMENT HALVES on to the ELEMENT MOUNTING BLOCKS. For each element insert a 1/4 x 10" Element Support Rod from the drilled end. Secure the rod / element assemblies to the element mounting blocks with the 8-32 x 1" screws and locknuts. Install screws from bottom of blocks.
3. Mount the longest element (REFLECTOR) to the hole at the rear end of the boom using a 8-32 x 2-1/4" screw and locknut. Tighten securely.
4. Mount the DRIVEN ELEMENT next, threading the 8-32 x 2" screw into the 'T' MATCH BLOCK held to the underside of the boom. Orient the match block with the "N" feed connector pointed to the front.
5. Mount the remaining DIRECTOR ELEMENTS using the element lengths specified on the Dimension Sheet. The dimensions taper in this design.
6. Thread the gold SEAL NUTS all the way onto the two small connectors on the 'T' match block **with the black neoprene side out**. Then connect the balun connectors and tighten them **GENTLY** with a 7/16" end wrench. Now run the seal nuts up against the face of the balun connectors and tighten them about 1/2 turn with a 1/2" end wrench. Secure coiled balun to boom with two nylon ties.
7. Install two 8-32 x 1/4" Setscrews into each SHORTING BAR. Then slide a SHORTING BAR onto each DRIVEN ELEMENT HALF and position per the dimension sheet. Align rods and element halves parallel and tighten the set screws with the 5/64" Allen wrench provided. NOTE: The half wave length balun does not have to be coiled up to work. It can be uncoiled and run along the boom backwards or preferably forward to move its weight more toward the center of the boom.

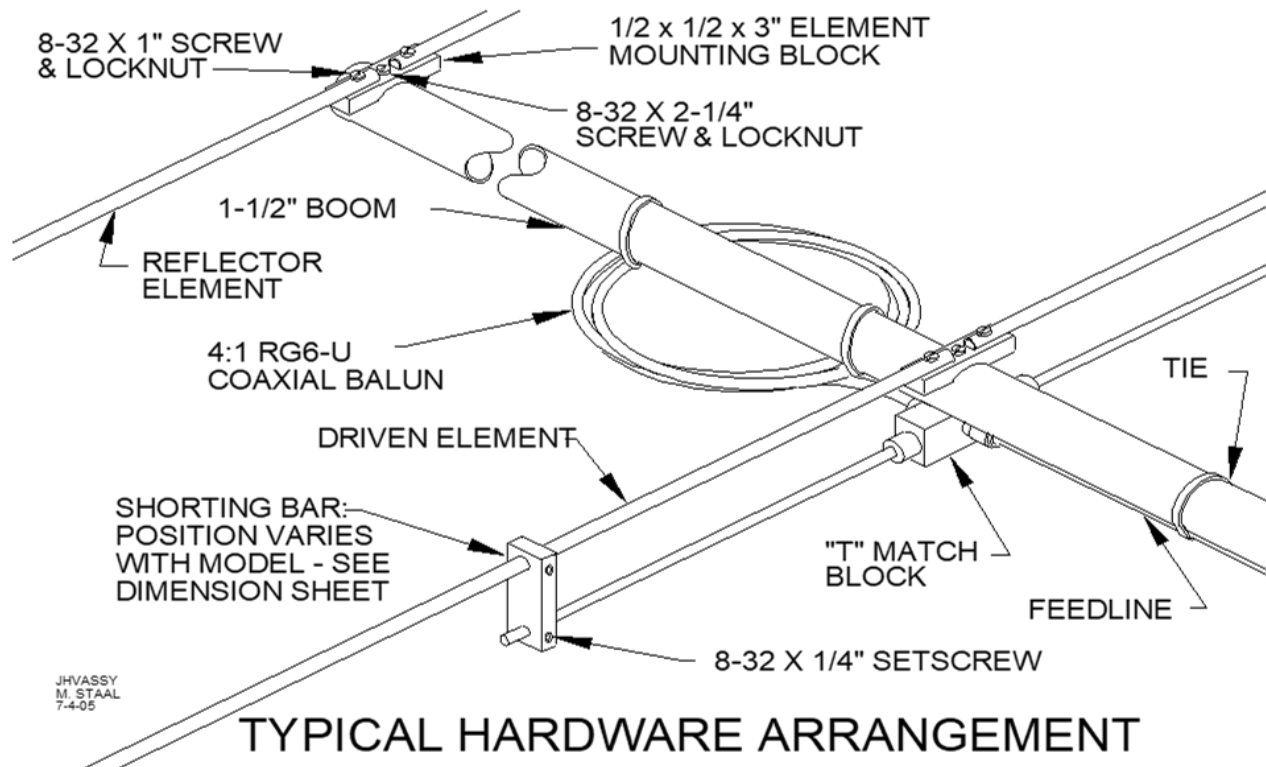

6M7JHV ASSEMBLY MANUAL

8. Install the main feedline, or a pigtail section just to get to the middle of the boom. Tighten the Male 'N' connector carefully, and route the cable forward on the boom, securing it with the cable ties provided.

9. Mount the BOOM TO MAST PLATE perpendicular to elements at the physical balance point of the antenna with the feedline installed. Secure with the 1-1/2" U-bolts, 5/16" stainless steel lockwashers and nuts. Tighten the U-bolts just enough to prevent the boom from sliding or rotating. Over-tightening can deform and weaken the boom. . 2" U-bolts are supplied for attaching plate to your mast.

10. Install the 1/4" x 4" EYEBOLTS to the front and rear boom sections, eyes up and parallel with boom. Secure with 1/4-20 locknuts.

11. To prepare the overhead guy system, begin by **temporarily** installing a 2" U-bolt through the 2" x 4" TURNBUCKLE PLATE and into the top set of 2" U-bolt holes on the boom to mast plate. Add a couple of 5/16" nuts to hold in place. Unscrew turnbuckle eyes / hooks until only a thread or two shows inside the turnbuckle body and hook to turnbuckle plate.

12. Uncoil KEVLAR CORD. Secure one end to rear eyebolt, taking two turns through the eyebolt, then adding three TIGHT half-hitches. Pull hard on cord to set the knots. Repeat for the front eyebolt. Seal cord ends with heat (lighter, propane torch, etc) and tape to main length.

13. Equalize cord length at turnbuckle plate and cut. Put two turns trough rear turnbuckle eye, pull slack out of rope, and add three TIGHT half-hitches. Repeat for front cord section. Seal and tape cord ends.

14. Both cords should now be fairly taut and parallel with boom. Disconnect the 2" U-bolt securing the turnbuckle plate and lift the turnbuckle plate up until the boom bows up slightly. This is approximately how high the plate will need to be mounted on the mast when the antenna is installed.

15. During final installation on the tower / mast, secure the turnbuckle plate at the appropriate height with the 2" U-bolt. Then lean or pull on the cords to increase the tension and help the knots take their final "set." Make sure the knots are not slipping. When the guy system has taken a "set", readjust the turnbuckle plate height until boom is straight and level. Finer adjustments can be made at any time, if necessary, with the turnbuckles. Safety-wire the turnbuckles to preserve settings.

16. When the antenna is installed in position on the mast, the main feedline can be attached and sealed at that time. REMEMBER to support the feedline at the antenna boom and on the mast. Leave an adequate feedline loop for rotation around the tower. When stacking this antenna with other HF models, maintain a minimum 5' of separation; more if practical. Mount horizontally polarized VHF and UHF antennas at least 40" above or below this antenna to minimize interaction.

17. INSTALLATION AND STACKING INFORMATION

A. A mast or crossboom that is mounted to the boom *in the element plane* must be non conductive (fiberglass, etc).

6M7JHV ASSEMBLY MANUAL

B. To protect your investment in this high performance antenna, always use high quality coax and connectors. Old, corroded, or poor quality materials are common sources of **serious** performance losses.

C. If possible, test the antenna, connectors and feedline BEFORE installing to your mast or tower. Set antenna on a tall ladder or temporary mast. Check for continuity and match across the bandwidth. It should be similar to rated specifications.

D. STACKING REMINDERS:

1. All driven element blocks **MUST** be oriented to the same side of boom.
2. All boom-to-mast plates **MUST** be mounted at the same point on the boom.
3. Feed / phasing lines **MUST** be of equal electrical length or multiples of 1 wavelength in order to maintain equal phasing in the array. Improper phasing can severely deteriorate performance.
4. If you are unsure about stacking multiple antennas, please call **M²** and let us help you **DO IT RIGHT**

THIS COMPLETES THE ANTENNA ASSEMBLY.

Carefully manufactured by:

M² ANTENNA SYSTEMS, INC.

4402 N. Selland Ave.

Fresno, CA 93722

(559) 432-8873 Fax: 432-3059

www.m2inc.com Email: sales@m2inc.com

6M7JHV DIMENSION SHEET

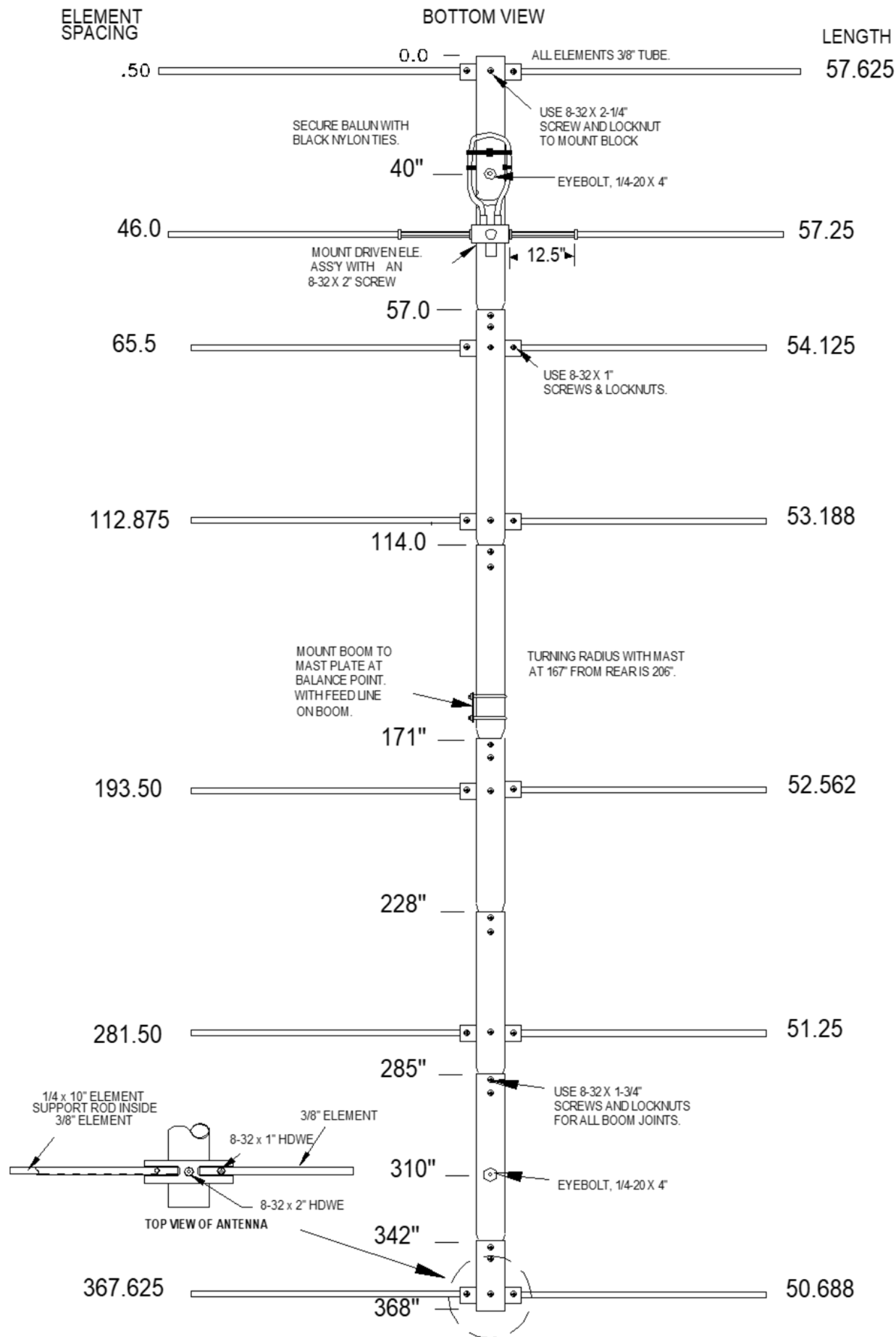

6M7JHV FT8 DIMENSION SHEET

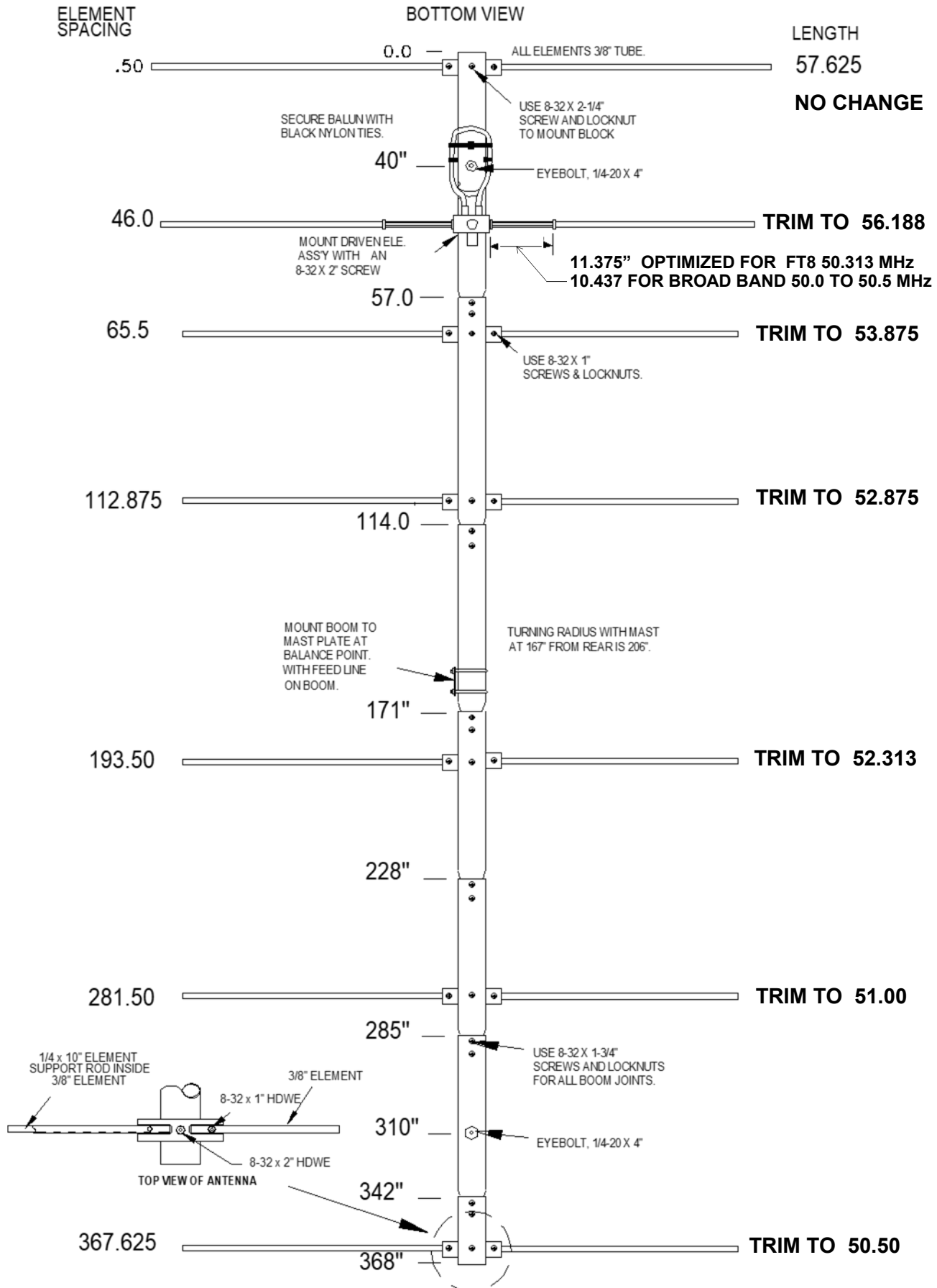

6M7JHV PARTS & HARDWARE

DESCRIPTION	QTY.
Boom Section #1to #6 1 1/2 x .065 x 60" SOE Alum.	6
Boom Section #7 1 1/2 x .065 x 26" plain. Alum.	1
Element half, 3/8 x .049 x see DIMENSION SHEET	14
Element Support Rod, 1/4 x 10" (M2AEP0060)	14
Driven `T' Match Assembly (SADEA6M7JHV)	1
Balun, 4:1, $\lambda/2$ @ 50.1 MHz, RG-6 (SABAL6M)	1
Dacron Rope, 3/16" x 24'	1
Boom Plate 4 x 6 x 3/16 Alum. (M2APT0022)	1
Assembly Instructions	1
 HARDWARE BAG#1	
U-Bolt & Cradle, 2"	3
U-Bolt & Cradle, 1 1/2"	2
 HARDWARE BAG #2	
Turnbuckle plate, 3/16 x 2 x 4" alum. (M2APT0101).....	1
Turnbuckle, 5/16"	2
Eyebolts, 1/4 x 4"	2
 HARDWARE BAG #3	
Element mounting blocks, 1/2 x 1/2 x 3"(M2AEC0056).....	7
Shorting bar, 1/4 x 3/4 x 2.875" mach. alum. (M2ASB0093).....	2
Nuts 5/16-18 SS.....	10
Lock Washers 5/16 Split Ring, ss.....	10
Nuts, 1/4-20 locking, ss	2
Screw, 8-32 x 2-1/4 panhead ss.....	6
Screw 8-32 X 2" panhead ss	1
Screw 8-32 x 1-3/4" panhead ss.....	12
Screw 8-32 x 1" panhead ss.....	14
Set Screw Internal Hex 8-32 x 1/4 ss	4
Locknut 8-32 ss.....	32
Cable Ties 8" Black	5
Allen Wrench 5/64"	1

M² ANTENNA SYSTEMS, INC.

4402 N. Selland Ave.

Fresno, CA 93722

(559) 432-8873 Fax: (559) 432-3059

www.m2inc.com Email: sales@m2inc.com